

CANADIAN PRICE LIST  
EFFECTIVE JAN. 1, 2003

# 2003 OMEGA LIFT ARM TELESCOPIC HANDLERS

**MODEL: ARM 10T55 - E**  
**10,000 LBS.**  
**55 FT. LIFT HEIGHT**

## ***STANDARD EQUIPMENT***

- TELESCOPIC 4 STAGE BOOM WITH REPLACEABLE WEAR PADS
- AUTOMATIC LOAD LEVELING
- ANGLE INDICATOR
- 122 HP TURBO DIESEL ENGINE (EMISSIONS CONTROL)
- POWER SHIFT - 3 FORWARD / 3 REVERSE SPEEDS
- ELECTRIC SHIFT WITH TORQUE CONVERTER
- PLANETARY 4WD
- 4 - WHEEL, ENCLOSED WET DISC BRAKES
- OSCILLATING REAR AXLE
- BATTERY - 12 VOLT, 1000 CCA
- 2 STAGE AIR CLEANER
- 48" OR 60" MASONRY/CARPENTRY CARRIAGE WITH CAGE
- GOODYEAR 17.5 X 25 12 PLY. TIRES WITH FLAT GUARD
- BRAKE ACCUMULATOR FOR DEAD ENGINE BRAKING
- OUTRIGGERS
- 2 - WHEEL, 4 - WHEEL, AND CRAB STEERING
- FRAME LEVELING WITH INDICATOR
- LOAD HOLDING VALVES ON CYLINDERS
- ROPS WITH GAUGES AND WARNING INDICATORS
- UNITIZED FRAME
- JOYSTICK BOOM CONTROL WITH SAFETY SWITCH
- QUICK ATTACH SYSTEM
- ENGINE BLOCK HEATER WITH EXTENSION CORD AND HOLDER
- INTERNAL SPRING APPLIED HYDRAULIC RELEASE/EMERGENCY BRAKE
- FRONT HEAD LIGHTS
- HORN AND BACK-UP ALARM
- 4 FENDERS
- 4 - WAY FLASHERS
- EMERGENCY BRAKE WITH TRANSMISSION DISCONNECT

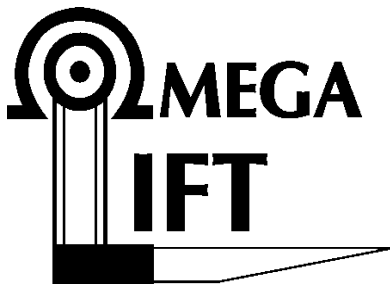

# SPECIFICATIONS

GENERAL	
Model	Omega Lift Arm 10T55 - E
Manufacturer	Omega Lift Manufacturing Inc.
Capacity	10,000 Lbs.
Engine:	
Manufacturer	Perkins Engines Inc.
Model Number and type	1004-4WT High Output
Horse Power	122 hp @ 2400 rpm
Number of Cylinders	4
Transmission	Clark-Hurth Equipment Co.
Axles	Clark-Hurth Equipment Co.
Radiator	Cancore Manufacturing Inc.
Brakes	4 Wheel, Hydraulic
Brake Valve, Service	Safim
Charging Valve	Safim
Battery	Interstate Battery
Tires:	
Manufacturer	Goodyear
Size, type	17.5 X 24, 12 Ply.
Pressure, Front	55 PSI
Rear	55 PSI
Hydraulic Pump	Parker

DIMENSIONS	
A. Ground Clearance (to counter weight)	19"
B. Wheelbase	114"
C. Overall length to carriage	252"
D. Top of cab.	112"
E. Maximum lift height	55'
F. Maximum forward reach	432"
G. Maximum vertical reach below grade	76"
* Maximum boom angle	73 °
* Overall width (without outriggers)	100"
* Overall width (with outriggers)	106"
* Turning radius	168"
* Shipping weight	30,400 Lbs.

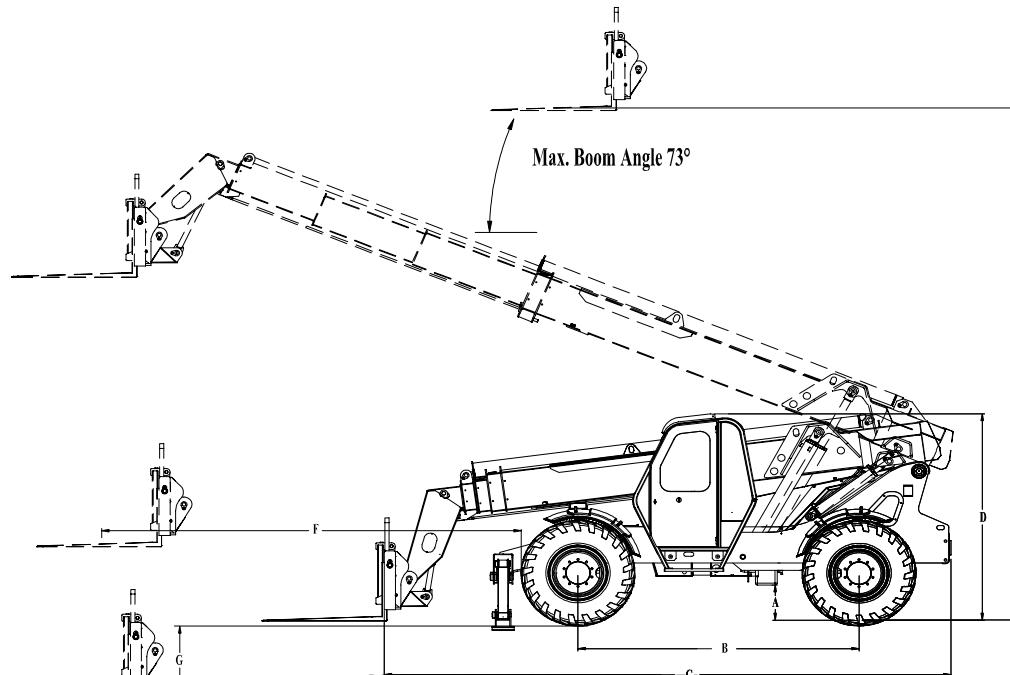

Omega Lift Manufacturing Inc. reserves the right to change these specifications without notice and without incurring any obligation relating to such change.