

## 2003 OMEGA LIFT VERTICAL MAST

**MODEL: 44XT- 8**  
**8,000 LBS.**  
**16 - 36 FT. LIFT HEIGHT**

### ***STANDARD EQUIPMENT***

- 2 - 4 STAGE I-BEAM ROLLER MAST
- CLEAR VIEW DESIGN
- 1004.4T TURBO DIESEL ENGINE
- POWER SHIFT - 3 FORWARD/3 REVERSE SPEEDS
- ELECTRIC SHIFT WITH TORQUE CONVERTER
- PARKING BRAKE DISK SYSTEM
- TRANSMISSION DISCONNECT ON PARKING BRAKE
- PLANATARY 4WD
- 4 - WHEEL, ENCLOSED WET DISC BRAKES
- BRAKE ACCUMULATOR FOR DEAD ENGINE BRAKING
- ADJUSTABLE SEAT WITH SEATBELT
- OSCILLATING REAR AXLE
- BATTERY – 12 VOLT, 120 AMP/HR. HEAVY DUTY
- 47 AMP ALTERNATOR
- INTERNAL SPRING APPLIED HYDRAULIC RELEASE/EMERGENCY BRAKE
- 2 STAGE AIR CLEANER
- 4' OR 4' \_ FORKS
- 48" OR 60" CARRIAGE
- GOODYEAR 16.9 X 24 12 PLY. WITH TIRE SEALANT
- 2 - WHEEL, 4 - WHEEL CRAB STEERING
- FRAME LEVELING WITH INDICATOR
- SOLID STEEL FRAME
- FOPS WITH GAUGES AND WARNING INDICATORS
- LOAD HOLDING VALVES ON CYLINDERS
- ENGINE BLOCK HEATER WITH CORD
- FRONT LIGHTS
- HORN AND BACK-UP ALARM
- 4 - WAY FLASHERS

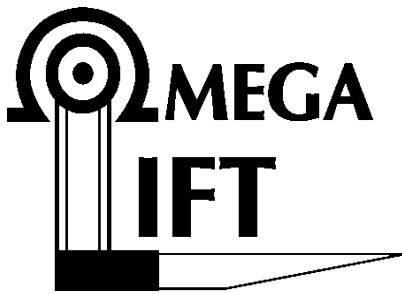

# SPECIFICATIONS

GENERAL	
Model	Omega Lift 4416T-8
Manufacturer	Omega Lift Manufacturing Inc.
Capacity	8,000 Lbs.
Engine:	
Manufacturer	Perkins Engines Inc.
Model Number and type	1004.4T Turbo Diesel
Horse Power	110 hp @ 2400 rpm
Number of Cylinders	4
Transmission	Clark-Hurth Equipment Co.
Axles	Clark-Hurth Equipment Co.
Radiator	Cancore Manufacturing Inc.
Brakes	4 Wheel, Hydraulic
Brake Valve, Service	Safim
Charging Valve	Safim
Battery	Interstate Battery
Tires:	
Manufacturer	Goodyear
Size, type	16.9 X 24-12 Ply.
Pressure, Front	35 - 40 PSI
Rear	35 - 40 PSI
Hydraulic Pump	Parker

DIMENSIONS	
A. Ground Clearance (to counter weight)	18"
B. Wheelbase	91"
C. Overall length to carriage	161"
D. Top of canopy	104"
E. Closed height of standard mast	148"
F. Standard mast at full tilt for transport	114"
* Maximum lift height	16 ft
* Overall width	99"
* Turning radius	150"
* Shipping weight	16,800 Lbs.

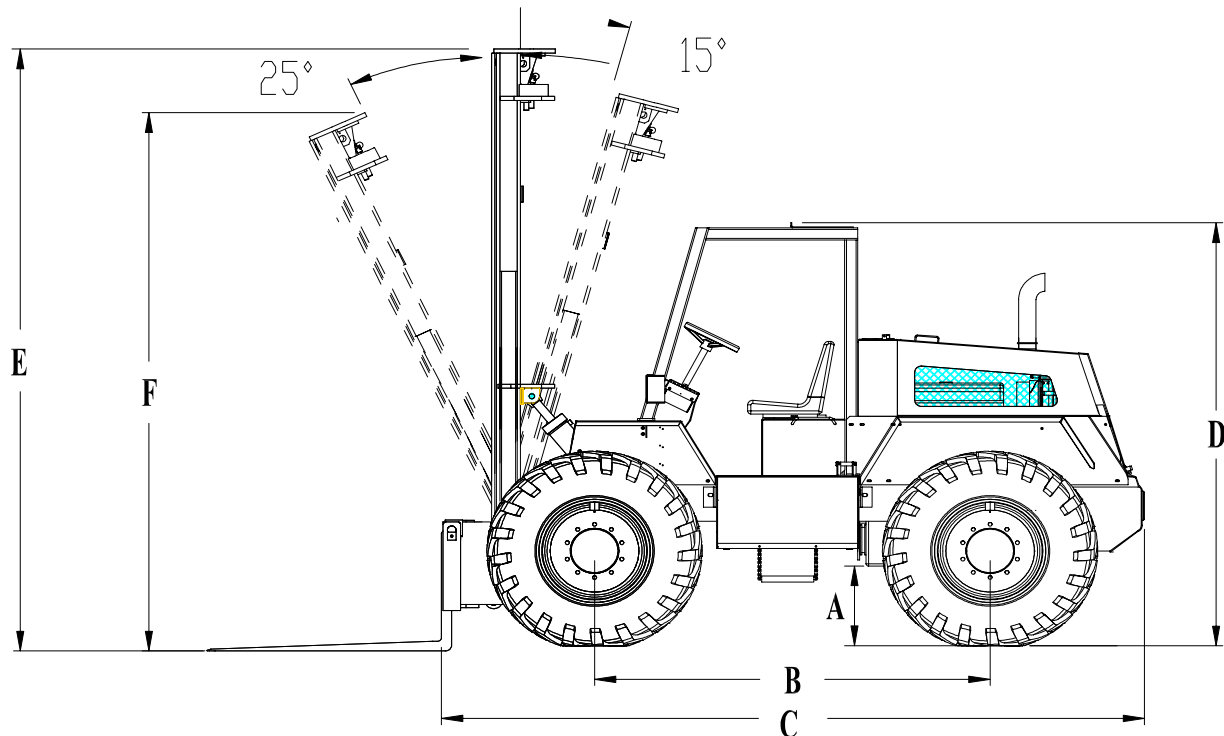

**8K (16' MAST) V-MAST**

Omega Lift Manufacturing Inc. reserves the right to change these specifications without notice and without incurring any obligation relating to such change.

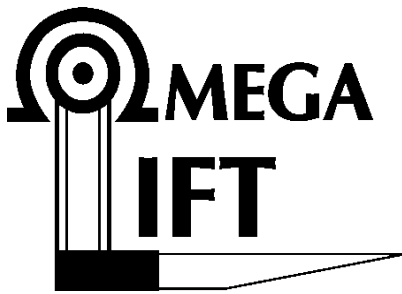

# SPECIFICATIONS

GENERAL	
Model	Omega Lift 4421T-8
Manufacturer	Omega Lift Manufacturing Inc.
Capacity	8,000 Lbs.
Engine:	
Manufacturer	Perkins Engines Inc.
Model Number and type	1004.4T Turbo Diesel
Horse Power	110 hp @ 2400 rpm
Number of Cylinders	4
Transmission	Clark-Hurth Equipment Co.
Axles	Clark-Hurth Equipment Co.
Radiator	Cancore Manufacturing Inc.
Brakes	4 Wheel, Hydraulic
Brake Valve, Service	Safim
Charging Valve	Safim
Battery	Interstate Battery
Tires:	
Manufacturer	Goodyear
Size, type	16.9 X 24-12 Ply.
Pressure, Front	35 - 40 PSI
Rear	35 - 40 PSI
Hydraulic Pump	Parker

DIMENSIONS	
A. Ground Clearance (to counter weight)	18"
B. Wheelbase	91"
C. Overall length to carriage	161"
D. Top of canopy	104"
E. Closed height of standard mast	138"
F. Standard mast at full tilt for transport	114"
* Maximum lift height	21 ft
* Overall width	99"
* Turning radius	150"
* Shipping weight	17,260 Lbs

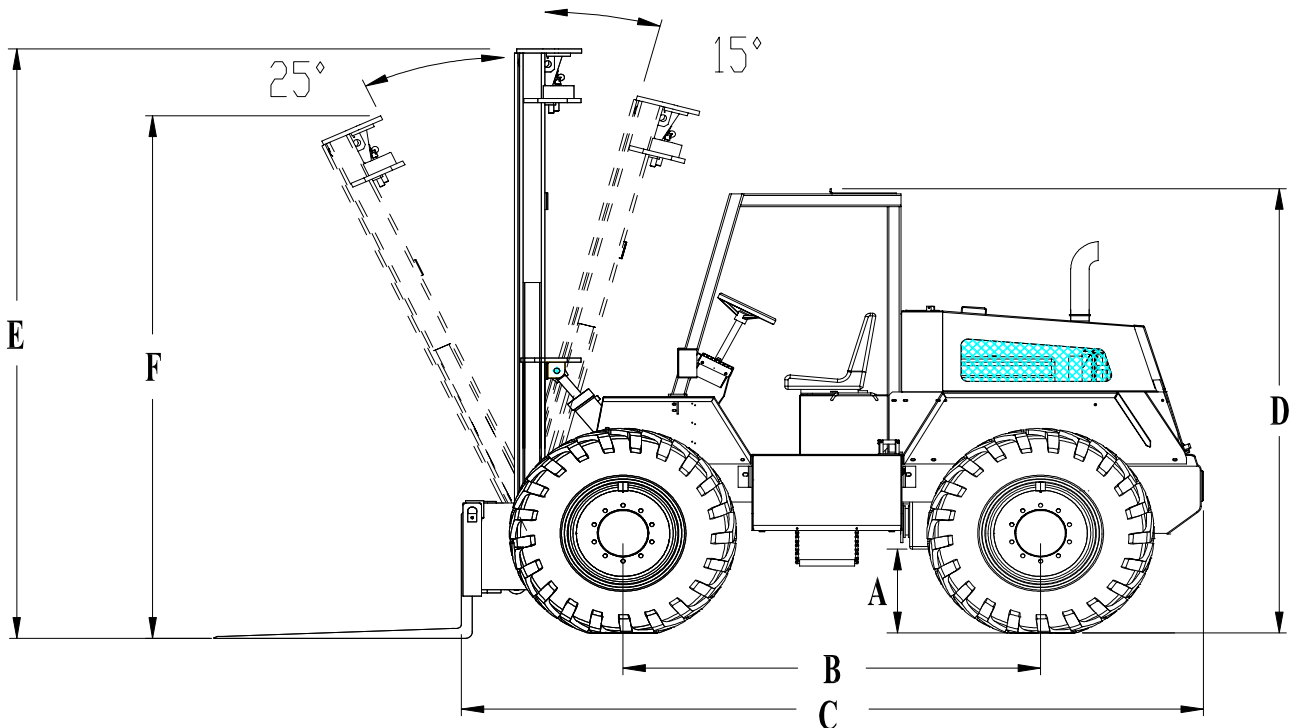

## 8K (21' MAST) V-MAST

Omega Lift Manufacturing Inc. reserves the right to change these specifications without notice and without incurring any obligation relating to such change.

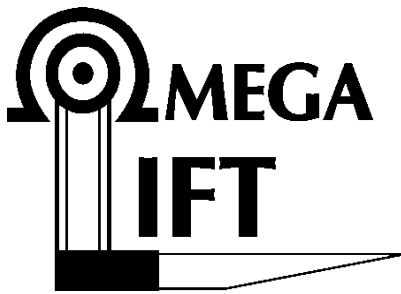

# SPECIFICATIONS

GENERAL	
Model	Omega Lift 4434T-8
Manufacturer	Omega Lift Manufacturing Inc.
Capacity	8,000 Lbs.
Engine:	
Manufacturer	Perkins Engines Inc.
Model Number and type	1004.4T Turbo Diesel
Horse Power	110 hp @ 2400 rpm
Number of Cylinders	4
Transmission	Clark-Hurth Equipment Co.
Axles	Clark-Hurth Equipment Co.
Radiator	Cancore Manufacturing Inc.
Brakes	4 Wheel, Hydraulic
Brake Valve, Service	Safim
Charging Valve	Safim
Battery	Interstate Battery
Tires:	
Manufacturer	Goodyear
Size, type	16.9 X 24-12 Ply.
Pressure, Front	35 - 40 PSI
Rear	35 - 40 PSI
Hydraulic Pump	Parker

DIMENSIONS	
A. Ground Clearance (to counter weight)	18"
B. Wheelbase	91"
C. Overall length to carriage	161"
D. Top of canopy	104"
E. Closed height of standard mast	160"
F. Standard mast at full tilt for transport	114"
* Maximum lift height	34 ft
* Overall width	99"
* Turning radius	150"
* Shipping weight	18,260 Lbs.

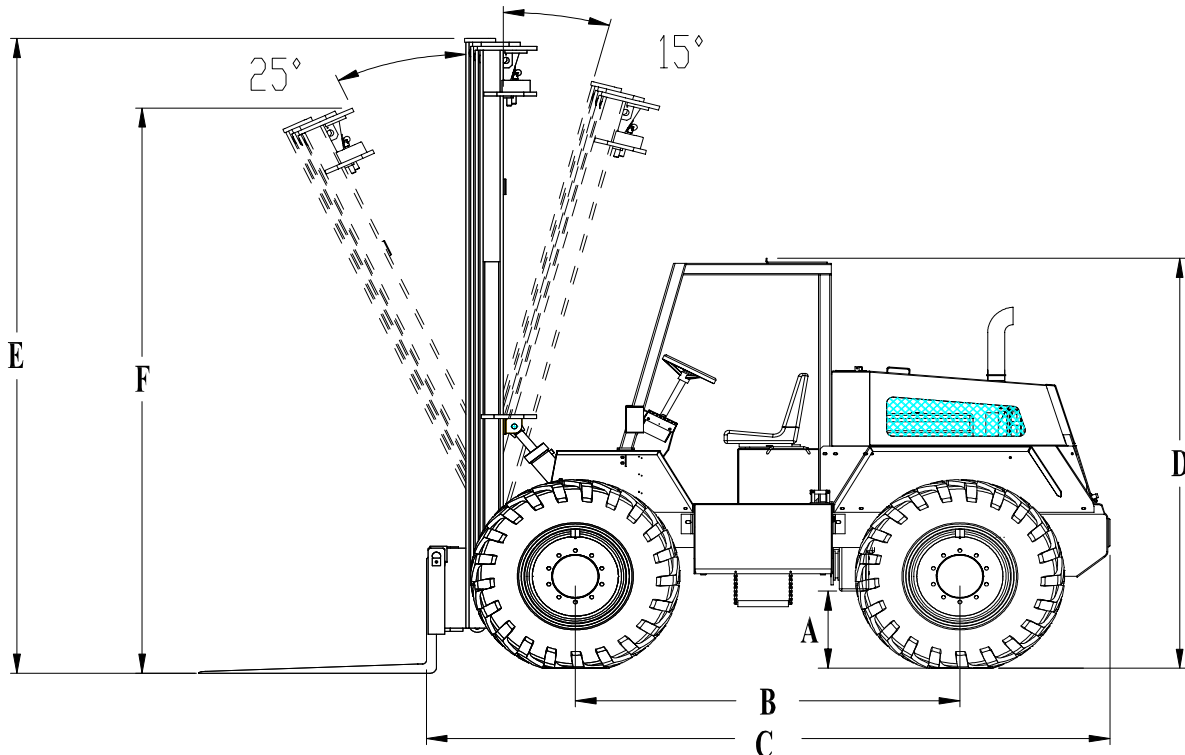

**8K (34' MAST) V-MAST**

Omega Lift Manufacturing Inc. reserves the right to change these specifications without notice and without incurring any obligation relating to such change.

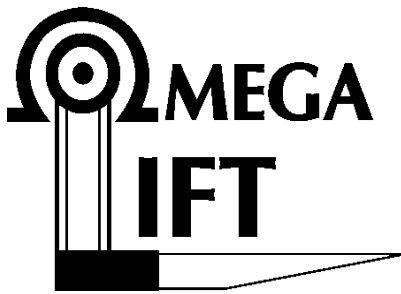

# SPECIFICATIONS

GENERAL	
Model	Omega Lift 4436T-8
Manufacturer	Omega Lift Manufacturing Inc.
Capacity	8,000 Lbs.
Engine:	
Manufacturer	Perkins Engines Inc.
Model Number and type	1004.4T Turbo Diesel
Horse Power	110 hp
Number of Cylinders	4
Transmission	Clark-Hurth Equipment Co.
Axles	Clark-Hurth Equipment Co.
Radiator	Cancore Manufacturing Inc.
Brakes	4 Wheel, Hydraulic
Brake Valve, Service	Safim
Charging Valve	Safim
Battery	Interstate Battery
Tires:	
Manufacturer	Goodyear
Size, type	16.9 X 24-12 Ply.
Pressure, Front	35 - 40 PSI
Rear	35 - 40 PSI
Hydraulic Pump	Parker

DIMENSIONS	
A. Ground Clearance (to counter weight)	18"
B. Wheelbase	91"
C. Overall length to carriage	161"
D. Top of canopy	104"
E. Closed height of standard mast	160"
F. Standard mast at full tilt for transport	114"
* Maximum lift height	36 ft
* Overall width	99"
* Turning radius	150"
* Shipping weight	18,260 Lbs.

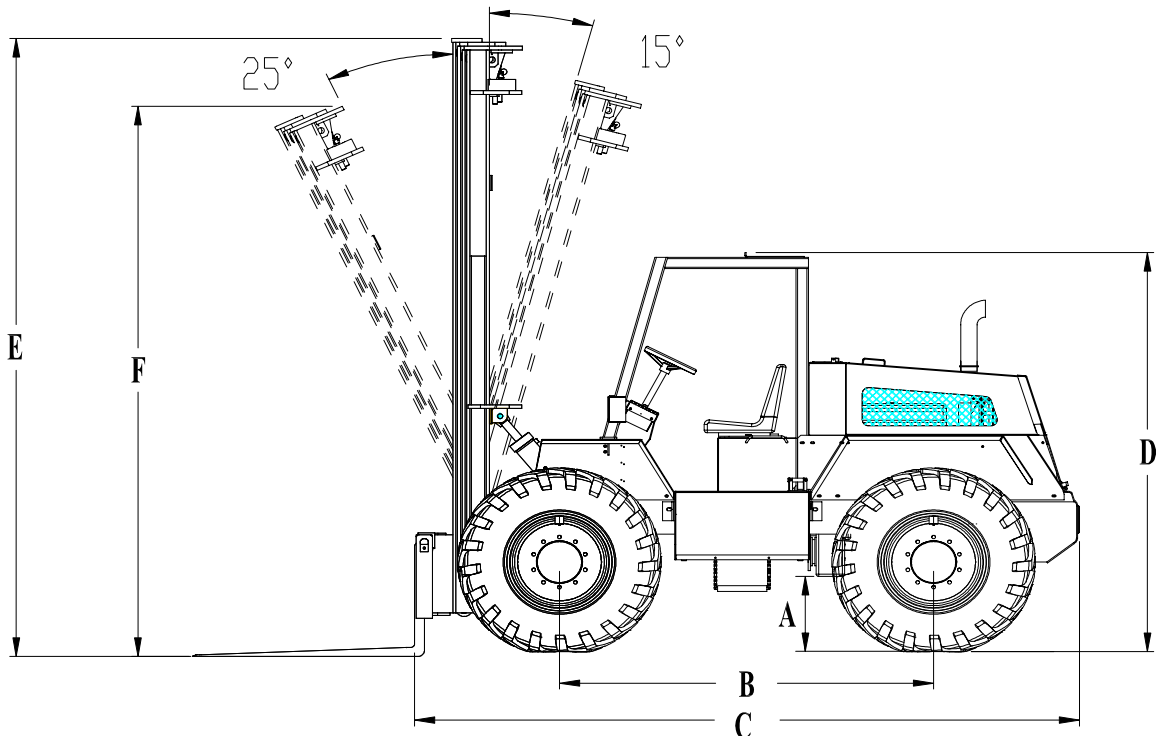

**8K (36' MAST) V-MAST**

Omega Lift Manufacturing Inc. reserves the right to change these specifications without notice and without incurring any obligation relating to such change.