

2003 OMEGA LIFT VERTICAL MAST

MODEL: 4412T - 16S
16,000 LBS.
12 FT. LIFT HEIGHT

STANDARD EQUIPMENT

- 2 STAGE 10" I-BEAM ROLLER MAST
- CLEAR VIEW DESIGN
- 1004.4WT TURBO DIESEL ENGINE
- POWER SHIFT - 3 FORWARD/3 REVERSE SPEEDS
- ELECTRIC SHIFT WITH TORQUE CONVERTER
- PARKING BRAKE DISK SYSTEM
- TRANSMISSION DISCONNECT ON PARKING BRAKE
- PLANATARY 4WD
- 4 - WHEEL, ENCLOSED WET DISC BRAKES
- BRAKE ACCUMULATOR FOR DEAD ENGINE BRAKING
- ADJUSTABLE SEAT WITH SEATBELT
- OSCILLATING REAR AXLE
- BATTERY - 12 VOLT, 120 AMP/HR. HEAVY DUTY
- 47 AMP ALTERNATOR
- INTERNAL SPRING APPLIED HYDRAULIC RELEASE/EMERGENCY BRAKE
- 2 STAGE AIR CLEANER
- 7' FORKS
- 60" CARRIAGE
- GOODYEAR SGL D/L2A 17.25 12 PLY. or 1400 SERIES WITH TIRE SEALANT
- 2 - WHEEL, 4 - WHEEL CRAB STEERING
- FRAME LEVELING WITH INDICATOR
- SOLID STEEL FRAME
- FOPS WITH GAUGES AND WARNING INDICATORS
- LOAD HOLDING VALVES ON CYLINDERS
- ENGINE BLOCK HEATER WITH CORD
- FRONT LIGHTS
- HORN AND BACK-UP ALARM
- 4 - WAY FLASHERS

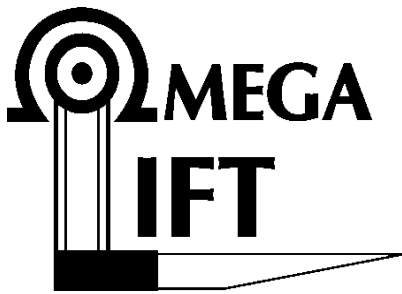

SPECIFICATIONS

GENERAL	
Model	Omega Lift 4412T-16S
Manufacturer	Omega Lift Manufacturing Inc.
Capacity	16,000 Lbs.
Engine:	
Manufacturer	Perkins Engines Inc.
Model Number and type	1004.4WT High Output
Horse Power	122 hp @ 2400 rpm
Number of Cylinders	4
Transmission	Clark-Hurth Equipment Co.
Axles	Clark-Hurth Equipment Co.
Radiator	Cancore Manufacturing Inc.
Brakes	4 Wheel, Hydraulic
Brake Valve, Service	Safim
Charging Valve	Safim
Battery	Interstate Battery
Tires:	
Manufacturer	Goodyear
Size, type	SGL D/L2A 17.5-25 or 1400 Series 12 Ply or 16 Ply
Pressure, Front	50-55 PSI
Rear	50-55 PSI
Hydraulic Pump	Parker

DIMENSIONS	
A. Ground Clearance (to counter weight)	15"
B. Wheelbase	100.5"
C. Overall length to carriage	180"
D. Top of canopy	104"
E. Closed height of standard mast	115" - 120"
F. Standard mast at full tilt for transport	100"
* Maximum lift height	12 ft
* Overall width	99"
* Turning radius	172"
* Shipping weight	26,200 Lbs.

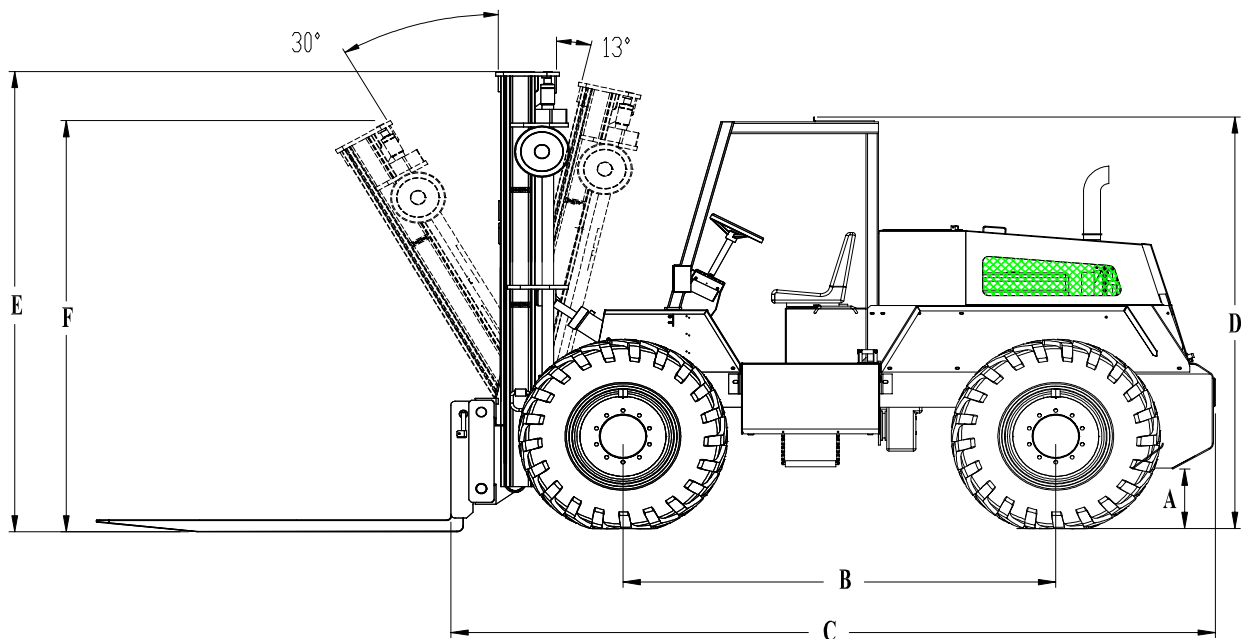

16K RECYCLERS SERIES

Omega Lift Manufacturing Inc. reserves the right to change these specifications without notice and without incurring any obligation relating to such change.